

Fitting instructions

Make: Chrysler / Dodge/
Lancia

Sebring (convertible); 2007->
Avenger; 2007->
Flavia; 2012->

Type: 4637

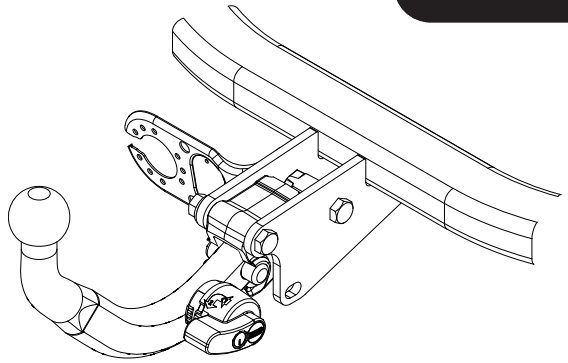



- NL Montagehandleiding
- GB Fitting instructions
- D Montageanleitung
- F Instructions de montage
- S Monteringsanvisningar
- DK Montagevejledning
- E Instrucciones de montaje
- I Istruzioni per il montaggio
- PL Instrukcja montażu
- SF Asennusohjeet
- CZ Pokyny k montáži
- H Szerelési útmutató
- RUS Руководство для монтажа

BRiNK[®]

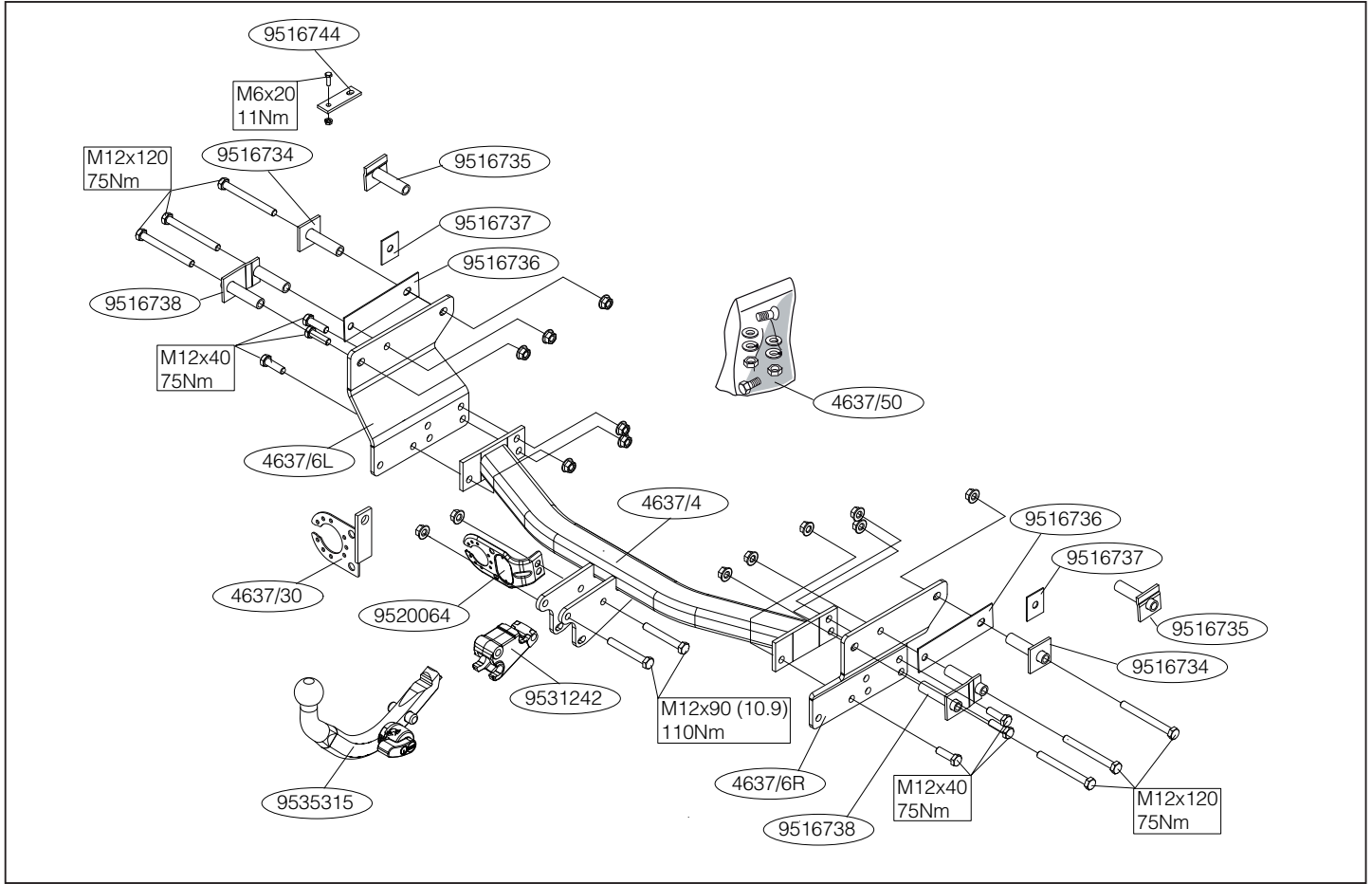
Your perfect fit
brink.eu

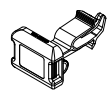
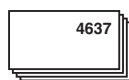
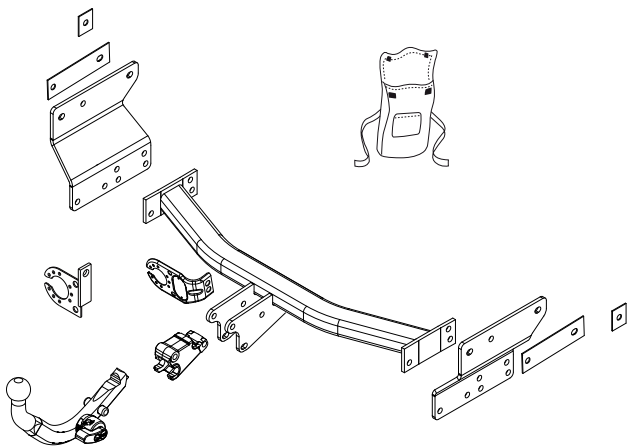
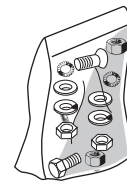
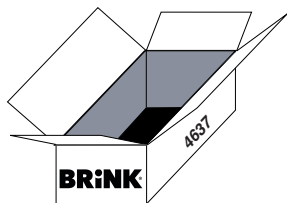





- 

(1x) M6x20



(1x) 25x5 L=80mm
- 

(6x) M12x40



(2x) Filling plate
- 

(2x) M12x90 (10.9)



(2x) Spacer
- 

(6x) M12x120



(2x) Spacer
- 

(1x) M6 (self-locking Flange Nut)



(2x) Spacer
- 

(14x) M12 (10) (self-locking Flange Nut)



(1x) socket plate

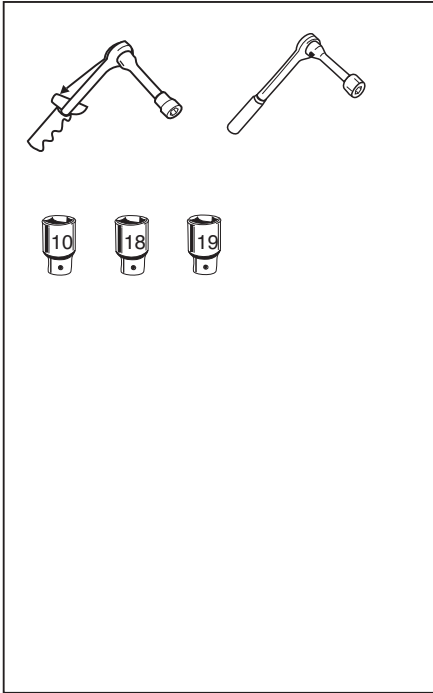

Couplingsclass: A50-X

Approved

e11 00-6364

94/20/EC

D-Value : 9,1 kN

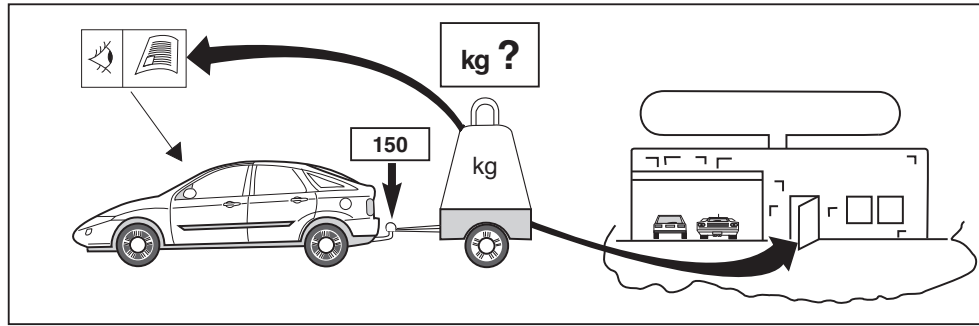

8.8

10.9

8

10

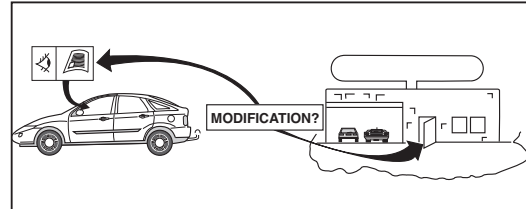



NOTE:

* Should this installation process entail the cutting of the bumper – confirmation **MUST** be obtained by the installation engineer of the customer's acceptance prior to completion. Brink Towing Systems do not accept responsibility for any matters arising as a result of this miscommunication.

All measurements are in mm!

HINWEISE:

* Die für das Fahrzeug zugelassene Anhängelast ist den Fahrzeug Unterlagen zu entnehmen. Bei Änderungen des Fahrzeuggewichtes muß die höchstzulässige Anhängelast gegebenenfalls aus dem D-Wert nachgerechnet werden.

Auskunft hierüber kann Ihr Fachhändler oder der TÜV geben.

* Elektrische Anlage gemäß StVZO anbringen.

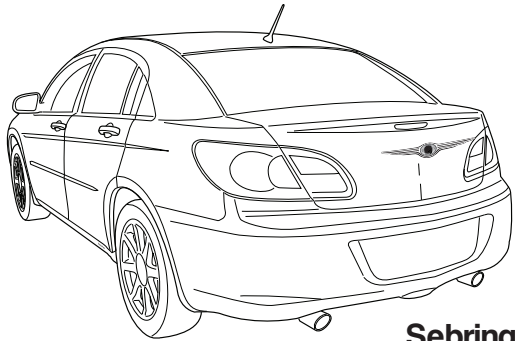

Sebring

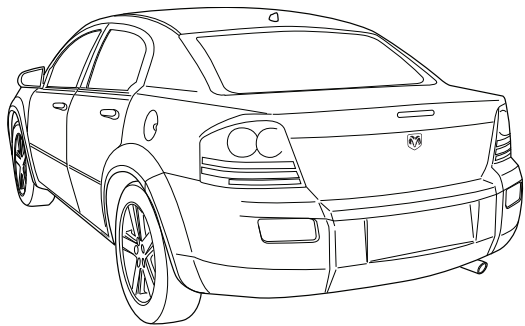

Avenger

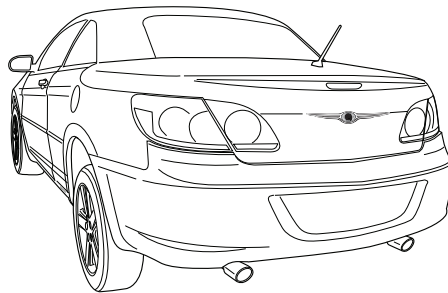
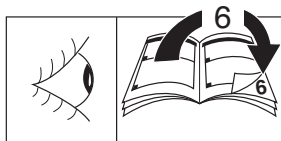



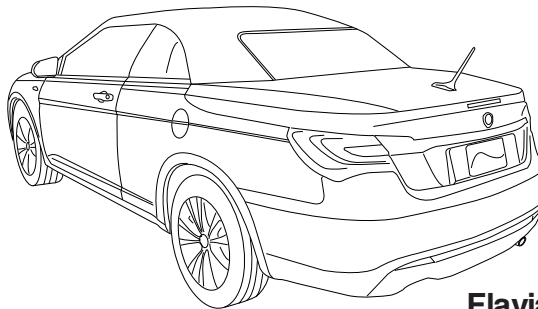





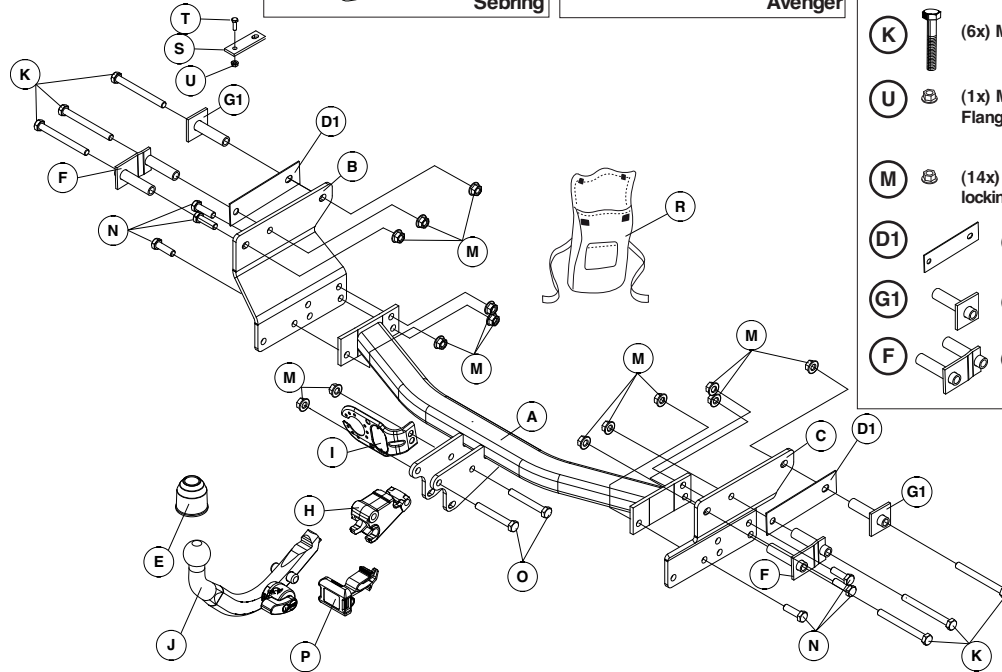
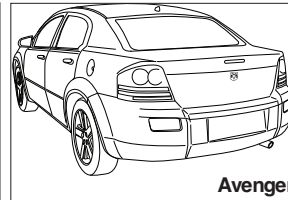
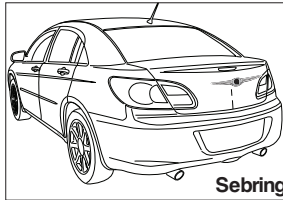









Sebring Convertible



Flavia





- | | | | | | |
|-----------|---|--|----------|---|-------------------|
| T |  | (1x) M6x20 | B |  | (1x) Side plate |
| N |  | (6x) M12x40 | C |  | (1x) Side plate |
| O |  | (2x) M12x90 (10.9) | H |  | (1x) housing |
| K |  | (6x) M12x120 | I |  | (1x) socket plate |
| U |  | (1x) M6 (self-locking Flange Nut) | J |  | (1x) ball |
| M |  | (14x) M12 (10) (self-locking Flange Nut) | P |  | (1x) dummy |
| D1 |  | (2x) Filling plate | E |  | (1x) ball cap |
| G1 |  | (2x) Spacer | R |  | (1x) Blue Bag |
| F |  | (2x) Spacer | S |  | (1x) 25x5 L=80mm |

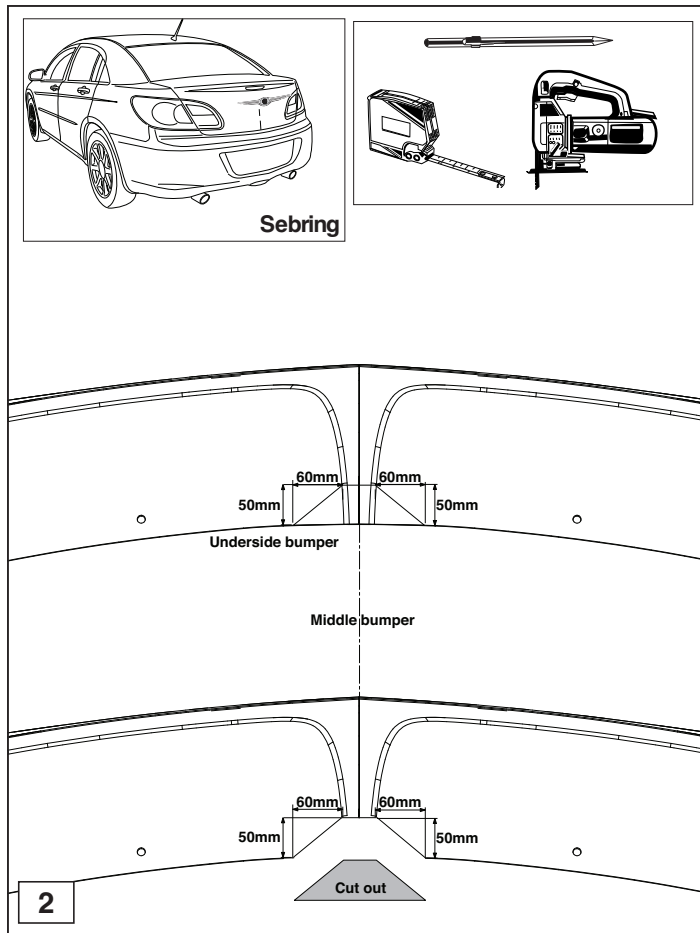
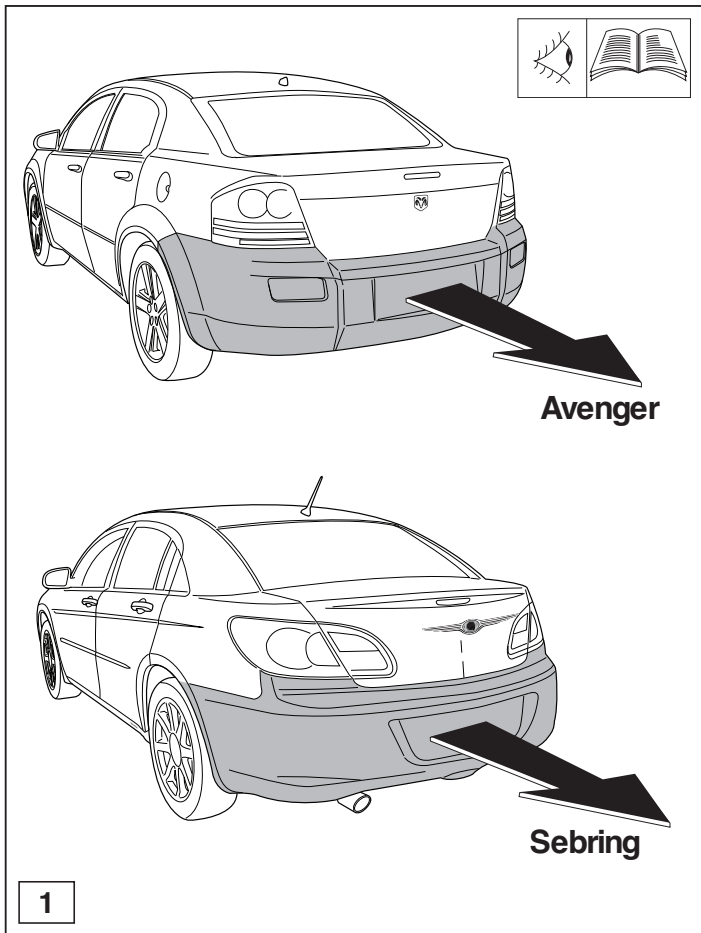

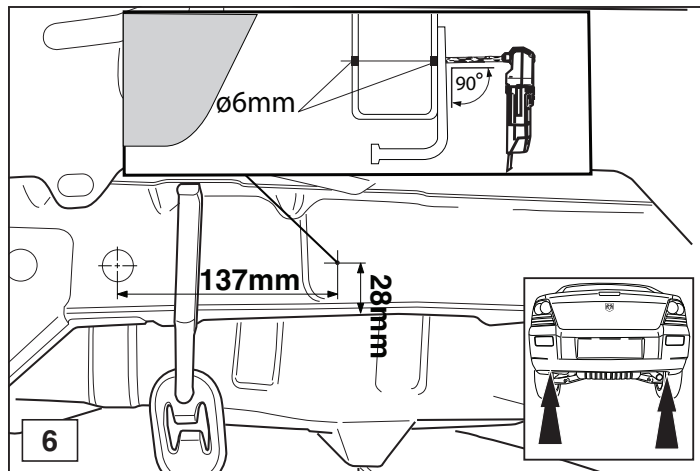
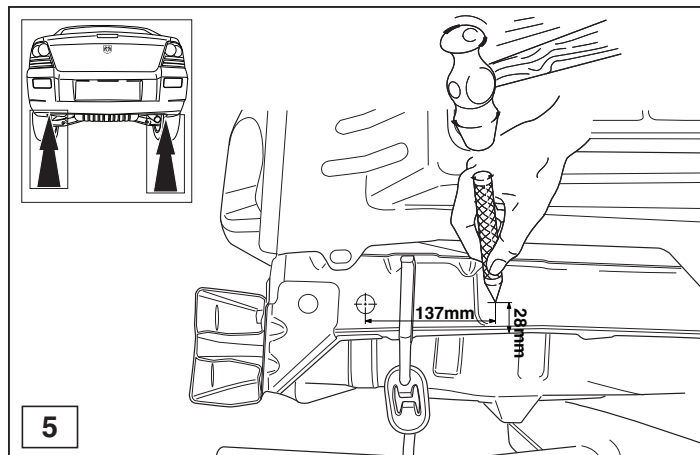
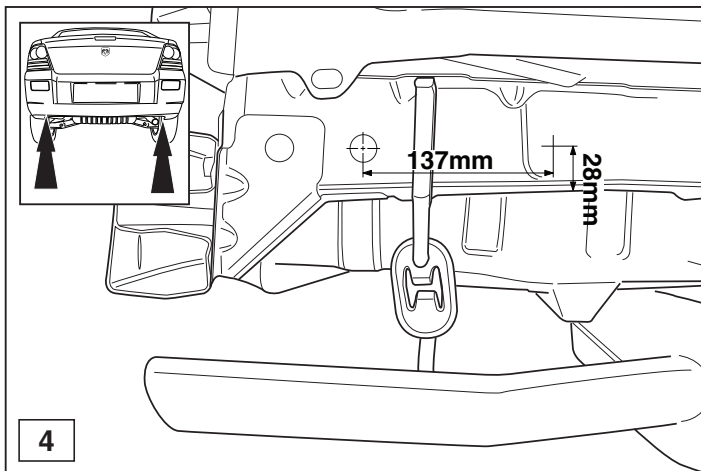
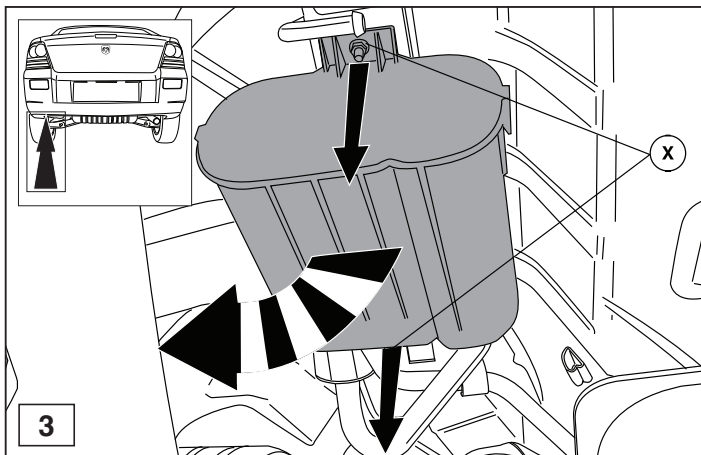

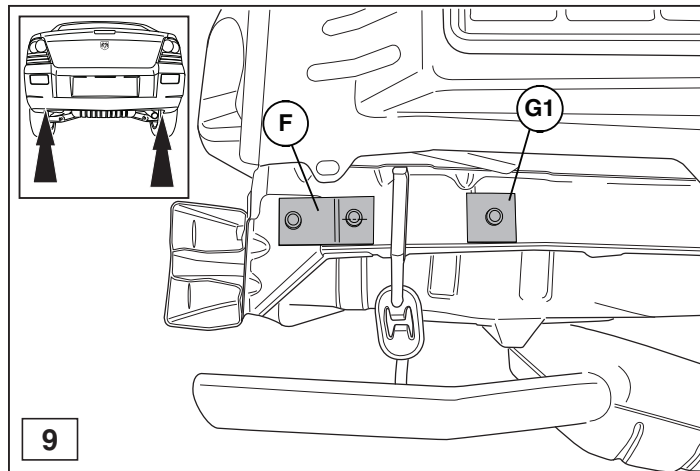
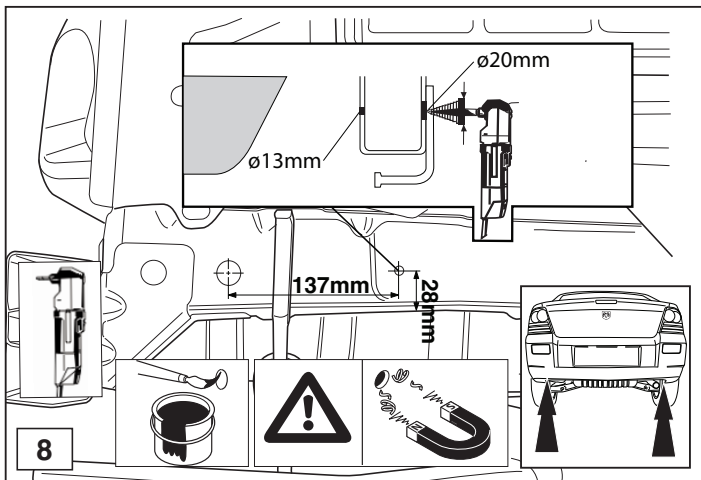
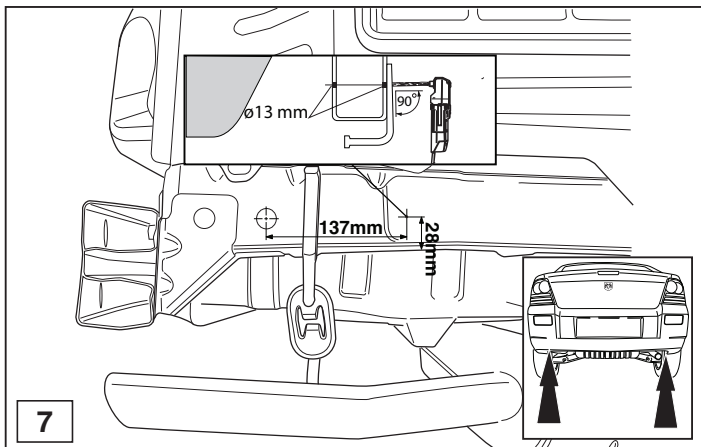

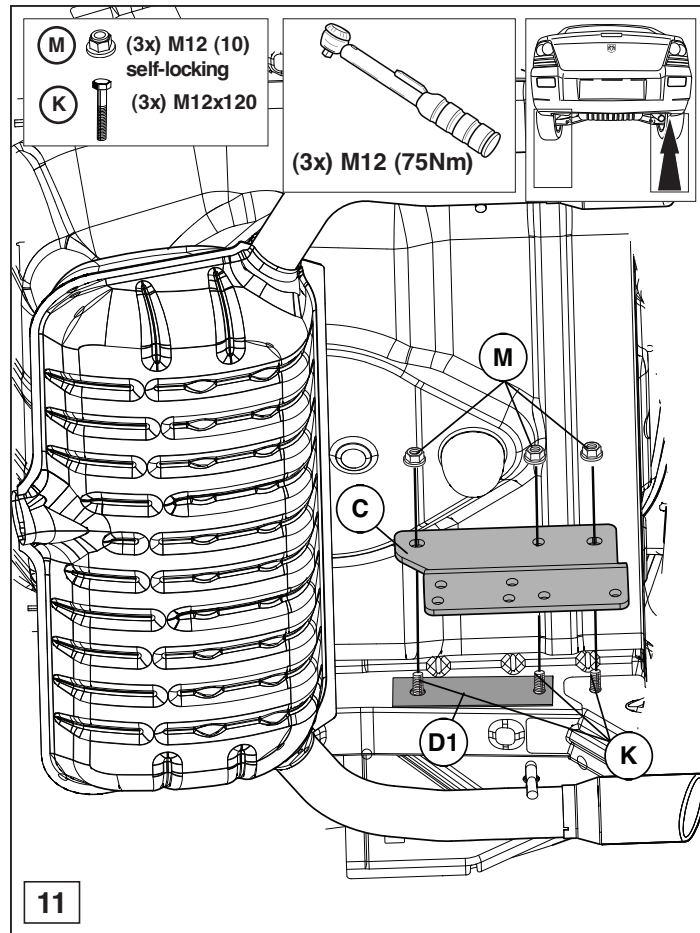
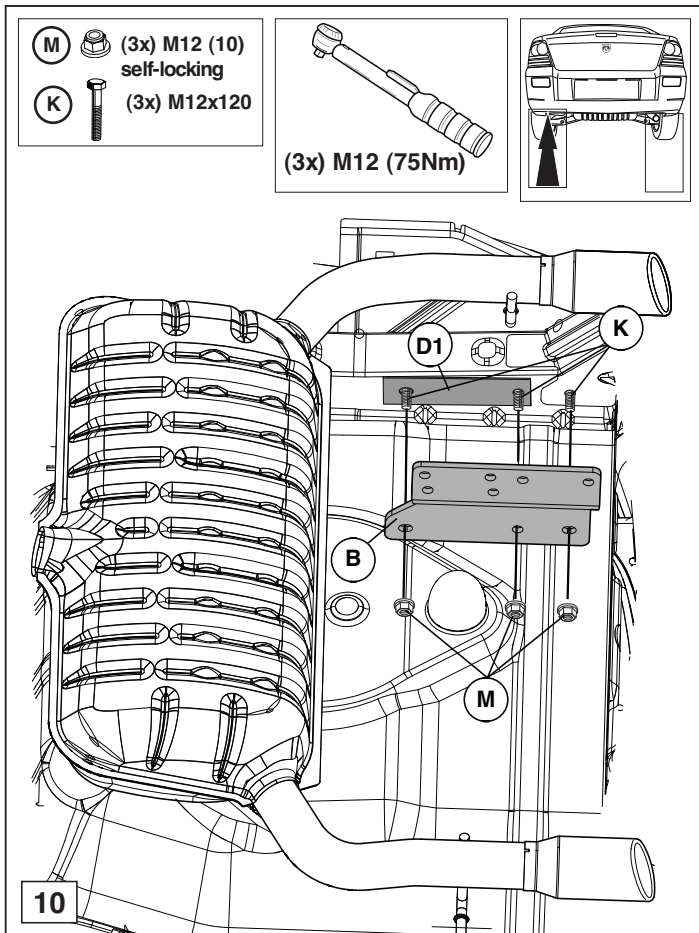

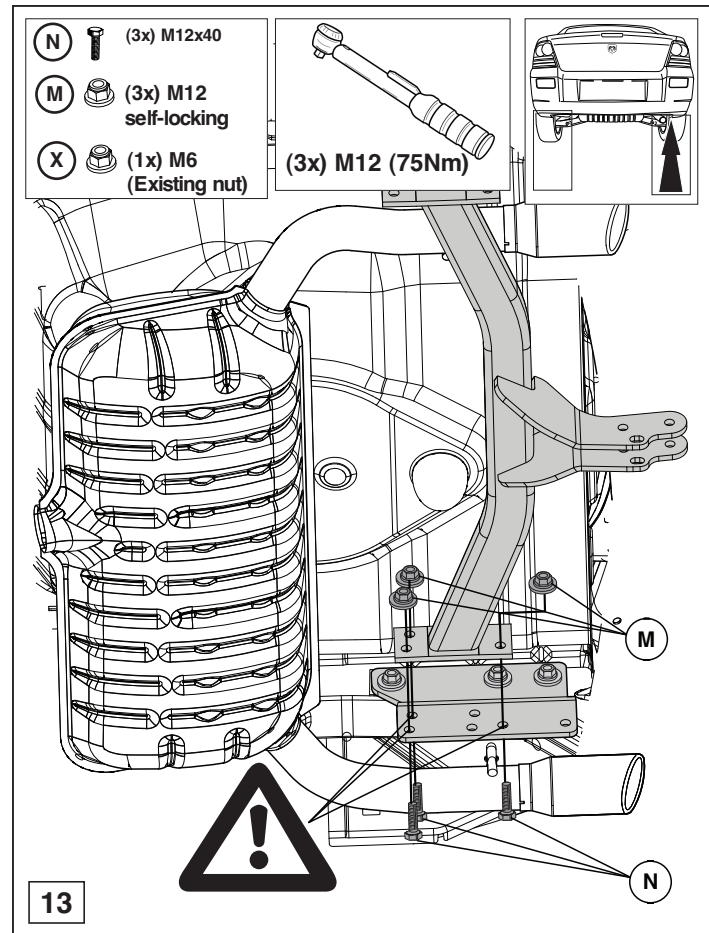
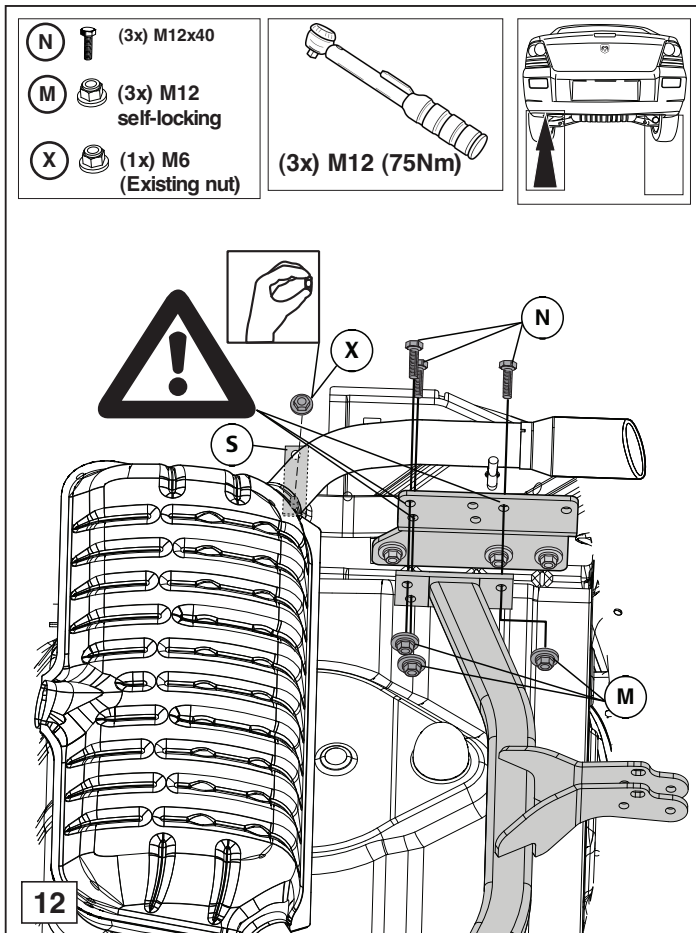

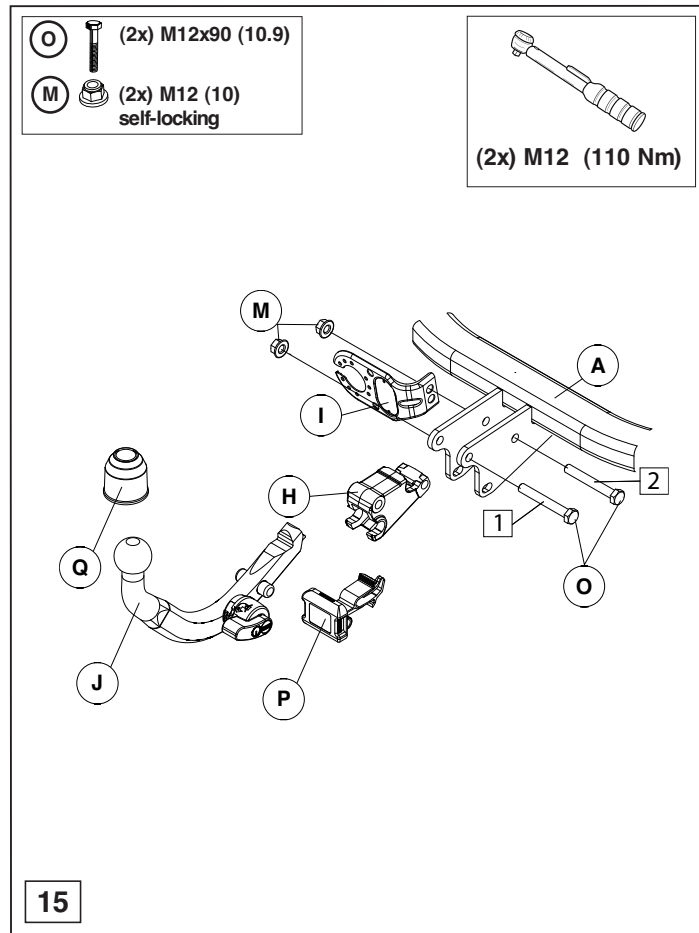
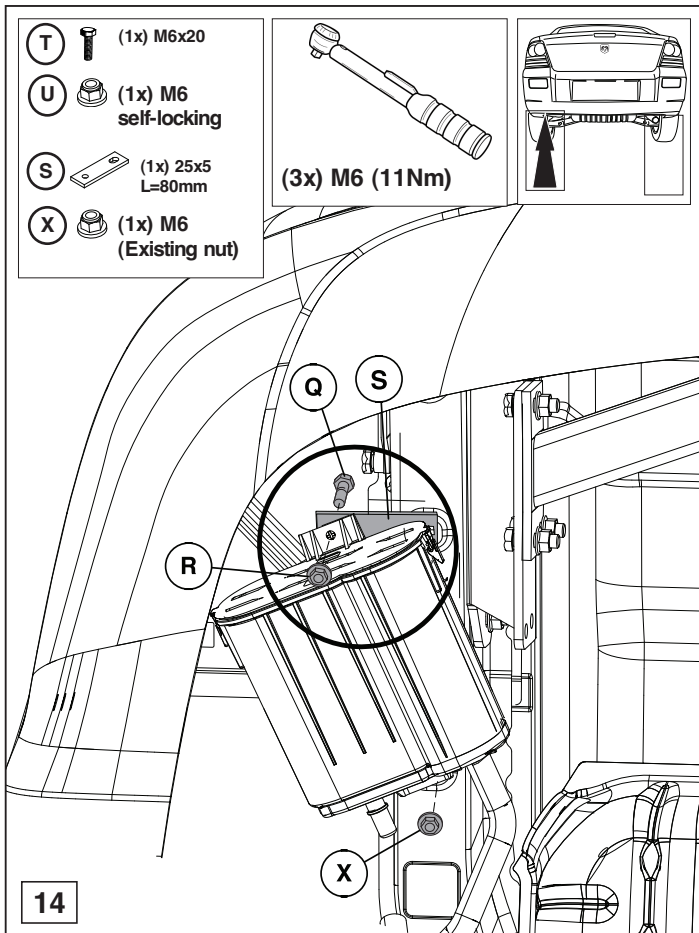

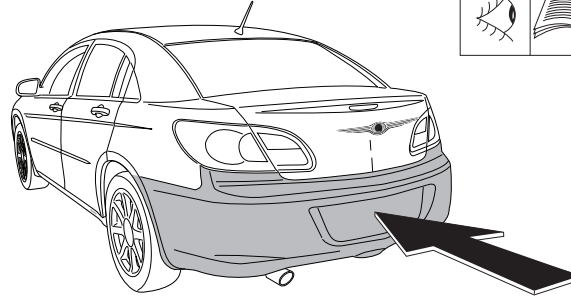

Sebring

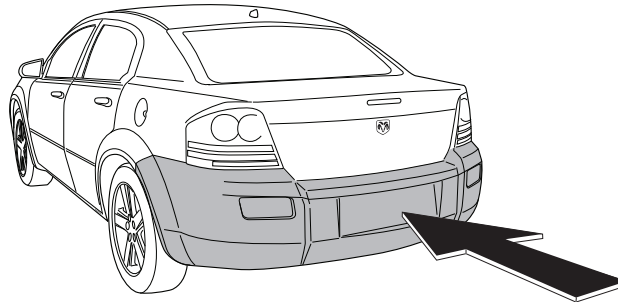



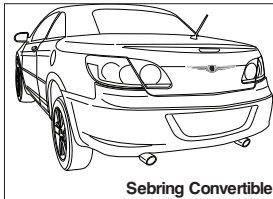



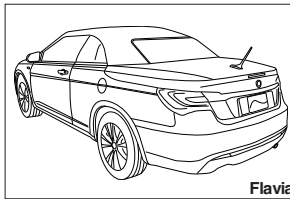











Avenger



Sebring Convertible



Flavia

- | | | | | | |
|-------------|---|-------------------------------------|------------|---|---------------------|
| (N) |  | (6x) M12x40 | (B) |  | (1x) Side plate |
| (O) |  | (2x) M12x90 (10.9) | (C) |  | (1x) Side plate |
| (K) |  | (6x) M12x120 | (H) |  | (1x) housing |
| (M) |  | (14x) M12 (self-locking Flange Nut) | (I) |  | (1x) socket plate |
| (D2) |  | (2x) Filling plate | (J) |  | (1x) ball |
| (G2) |  | (2x) Spacer | (P) |  | (1x) dummy Chrysler |
| (F) |  | (2x) Spacer | (E) |  | (1x) ball cap |
| (S) |  | (1x) Canister plate | (R) |  | (1x) Blue Bag |
| (T) |  | (1x) M6x20 | (Q) |  | (1x) socket plate |
| (U) |  | (1x) M6 (self-locking Flange Nut) | | | |

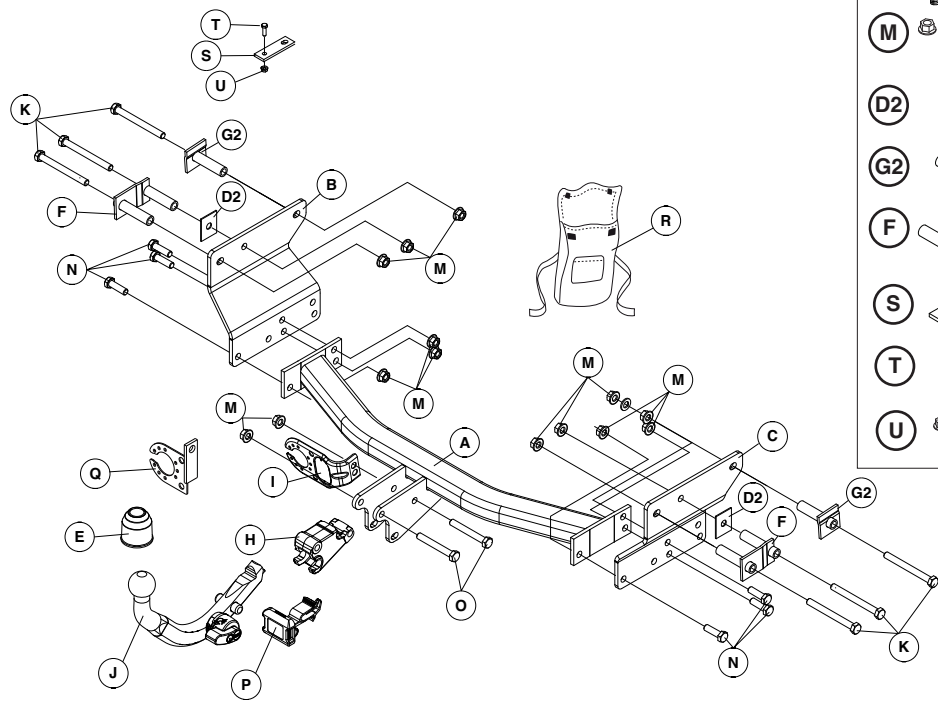

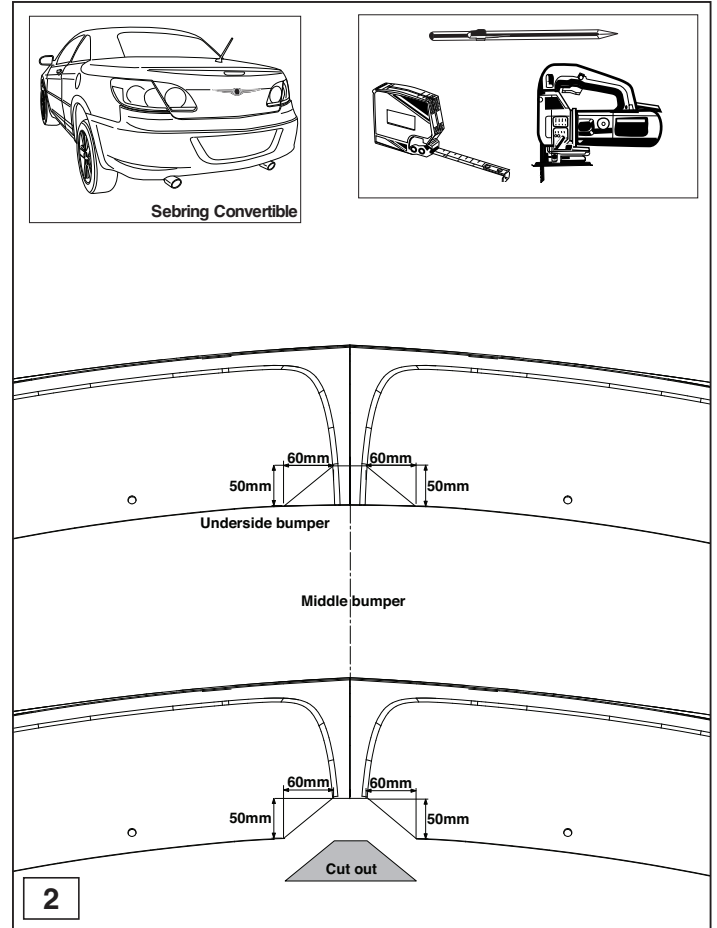
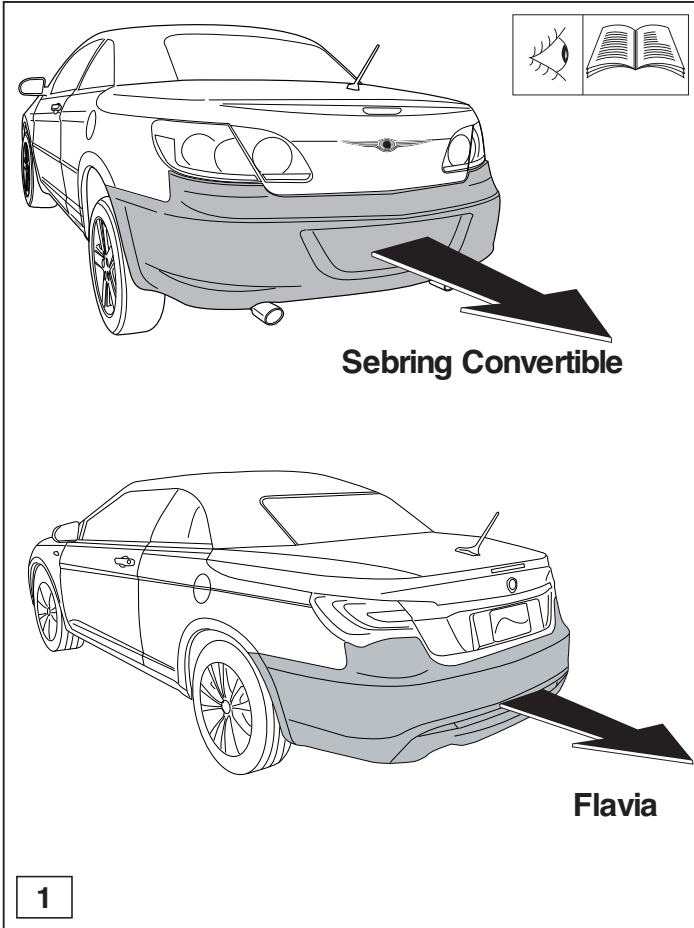

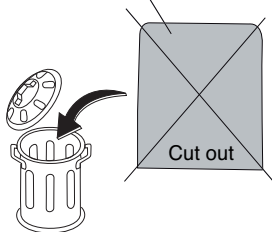
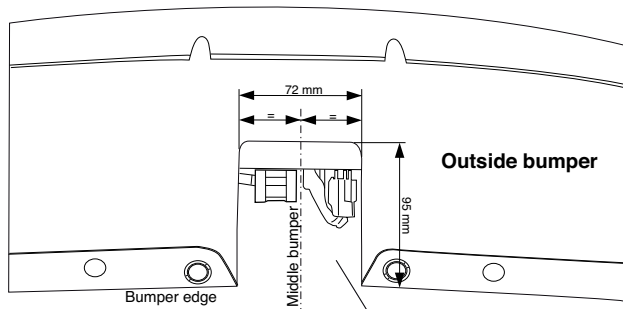
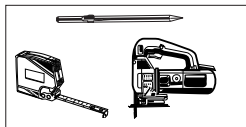
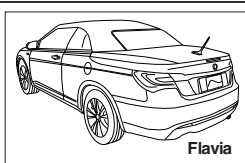

3

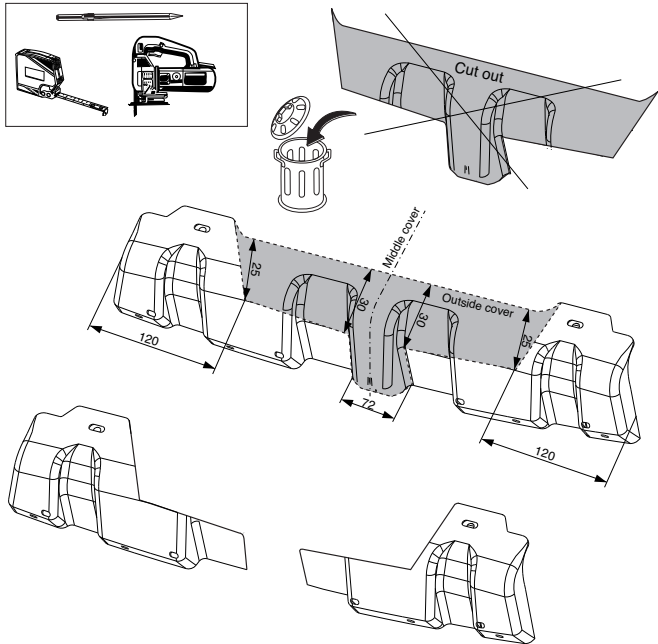
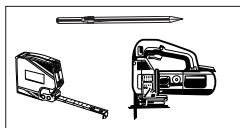
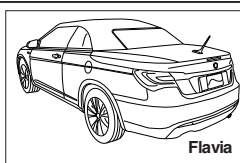

4

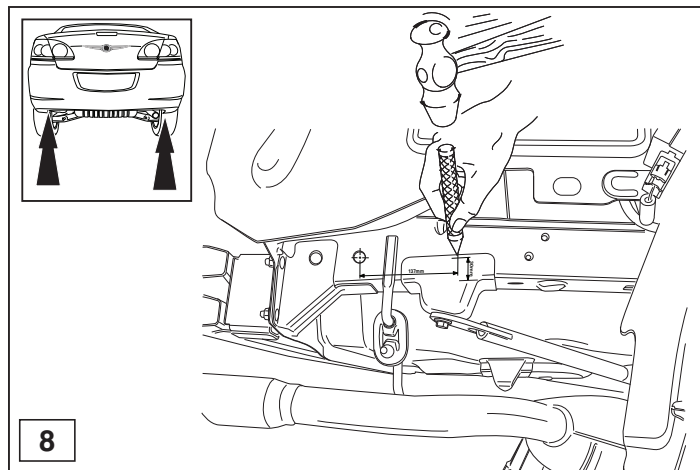
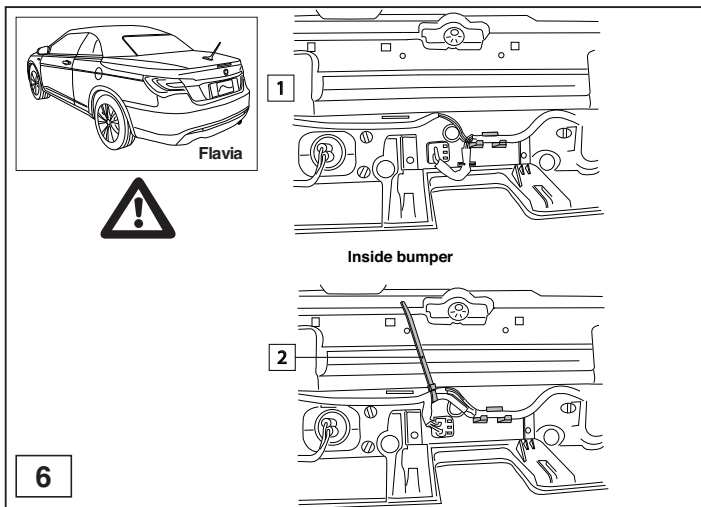
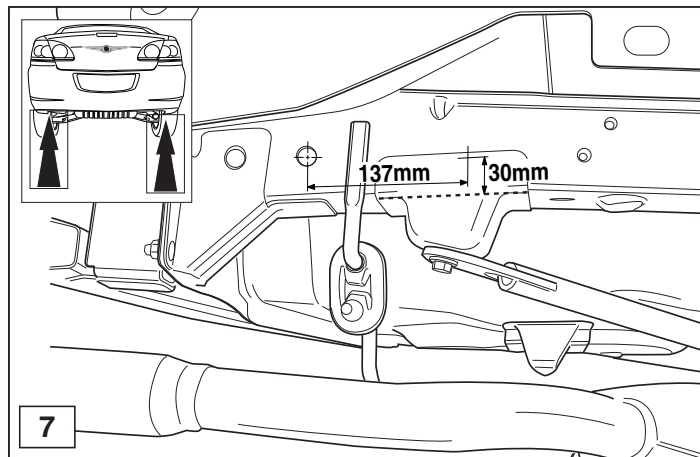
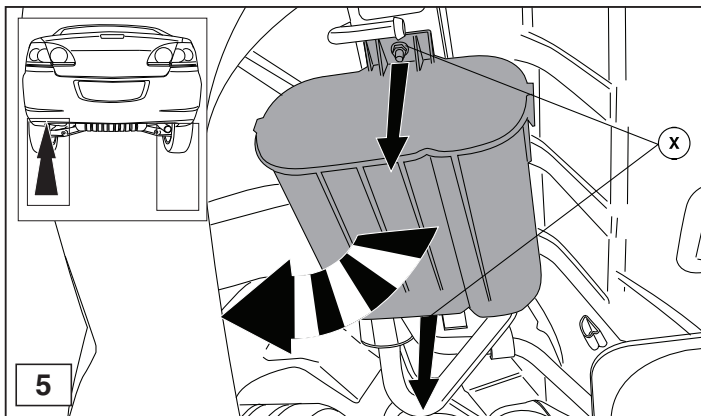

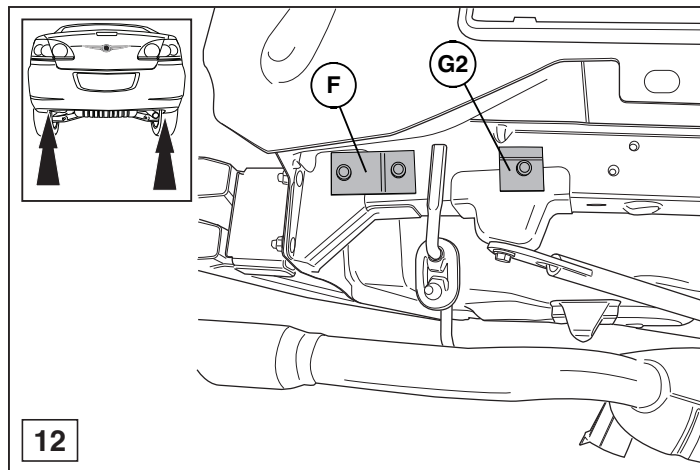
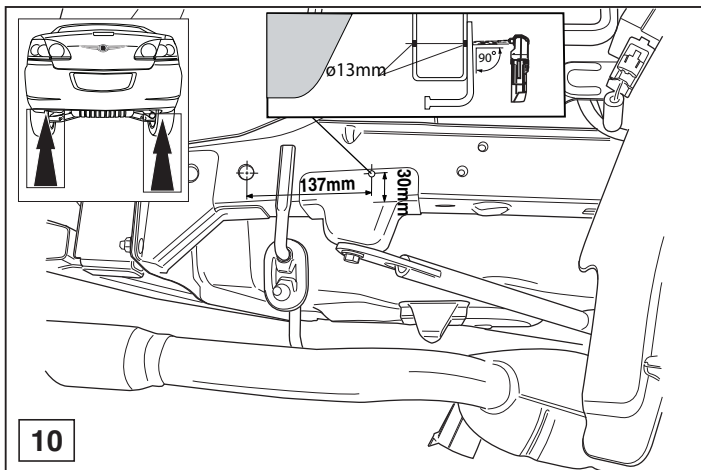
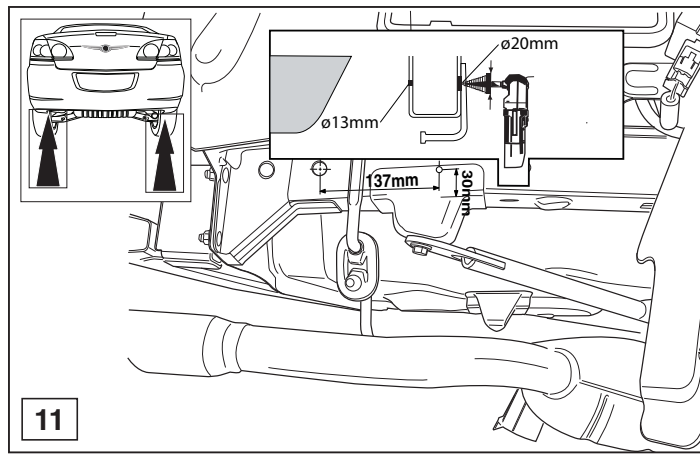
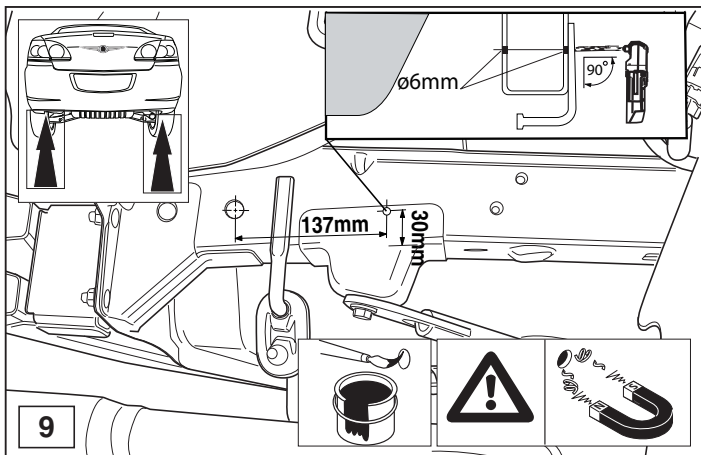

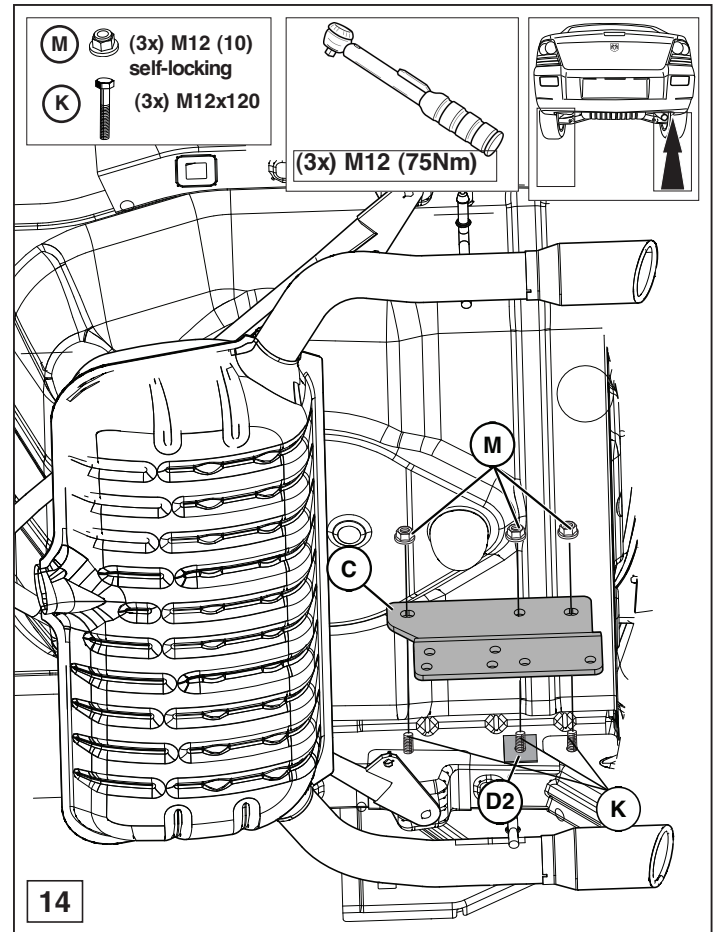
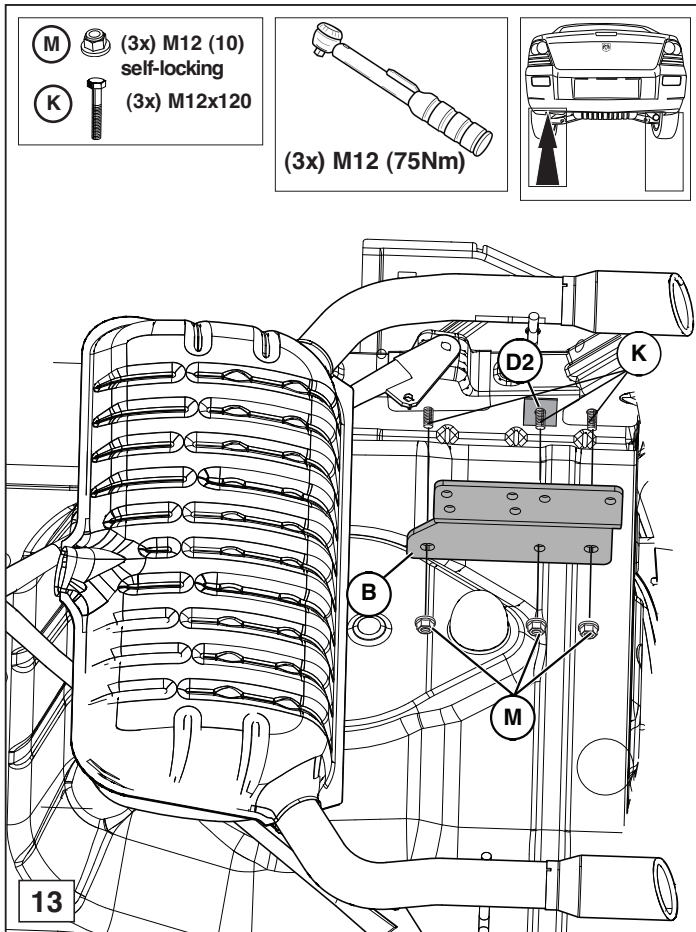

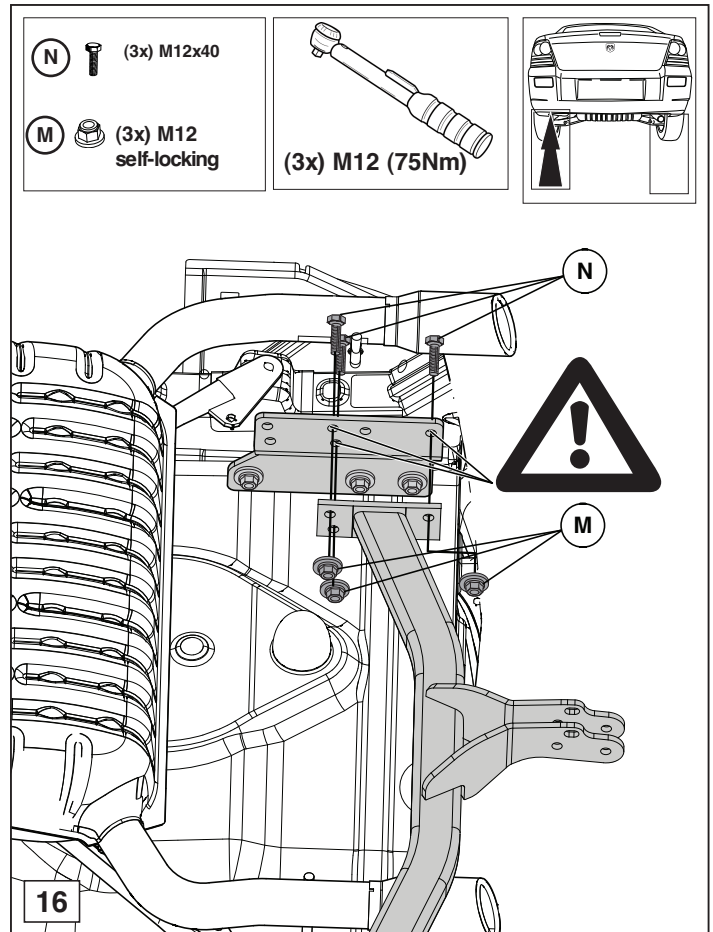
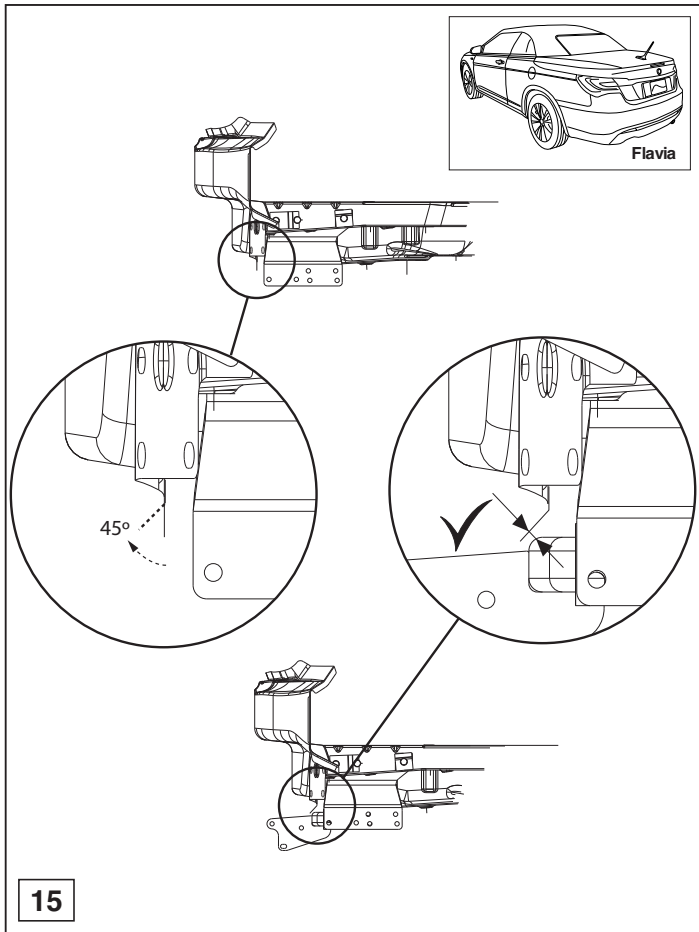

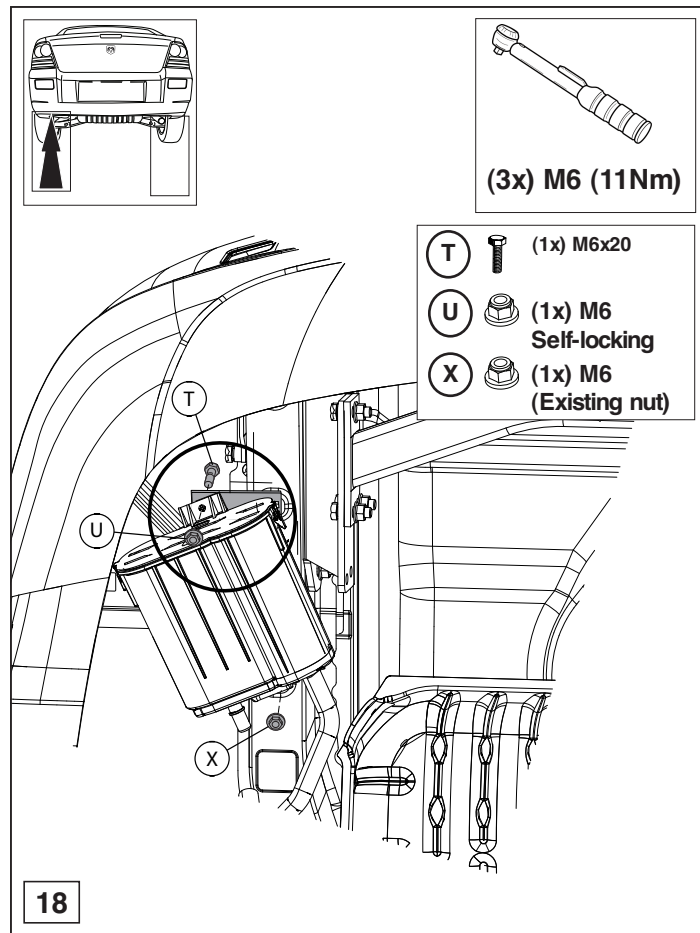
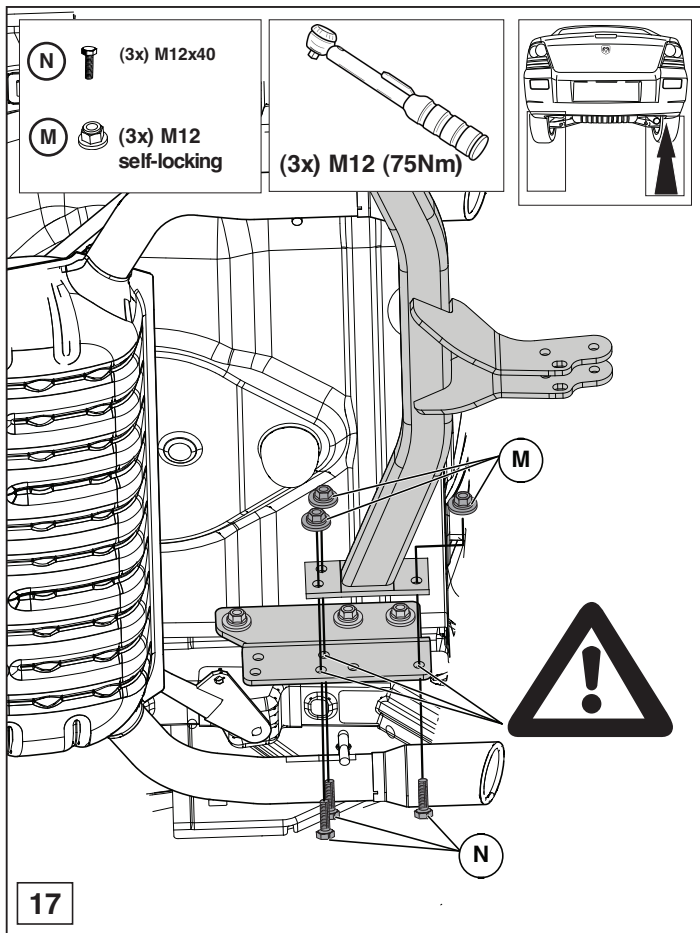

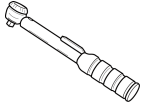

- O**  (2x) M12x90 (10.9)
- M**  (2x) M12 (10)
self-locking

- 
- (2x) M12 (110 Nm)

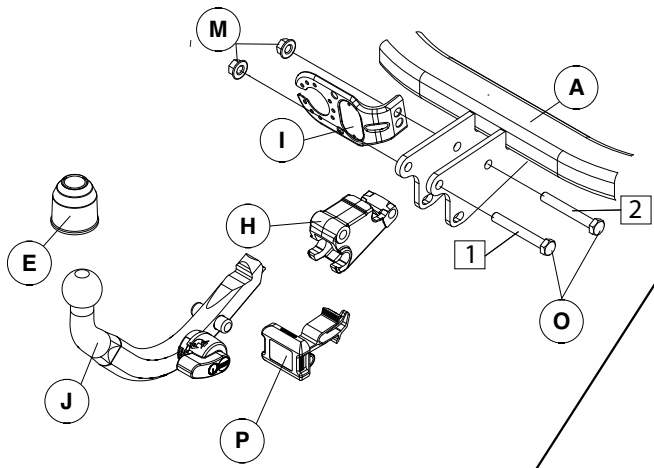

Sebring Convertible

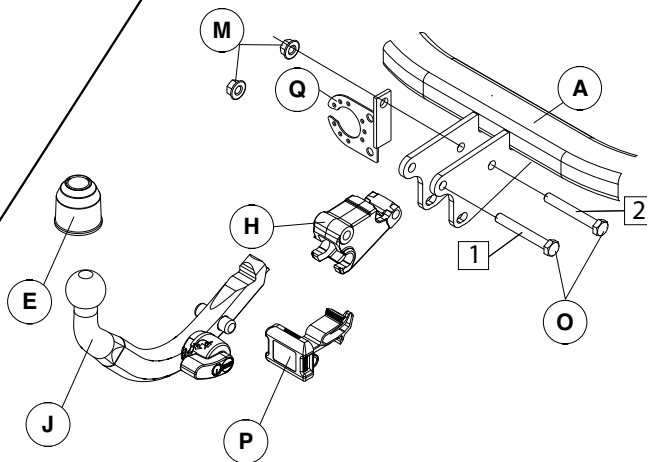

Flavia

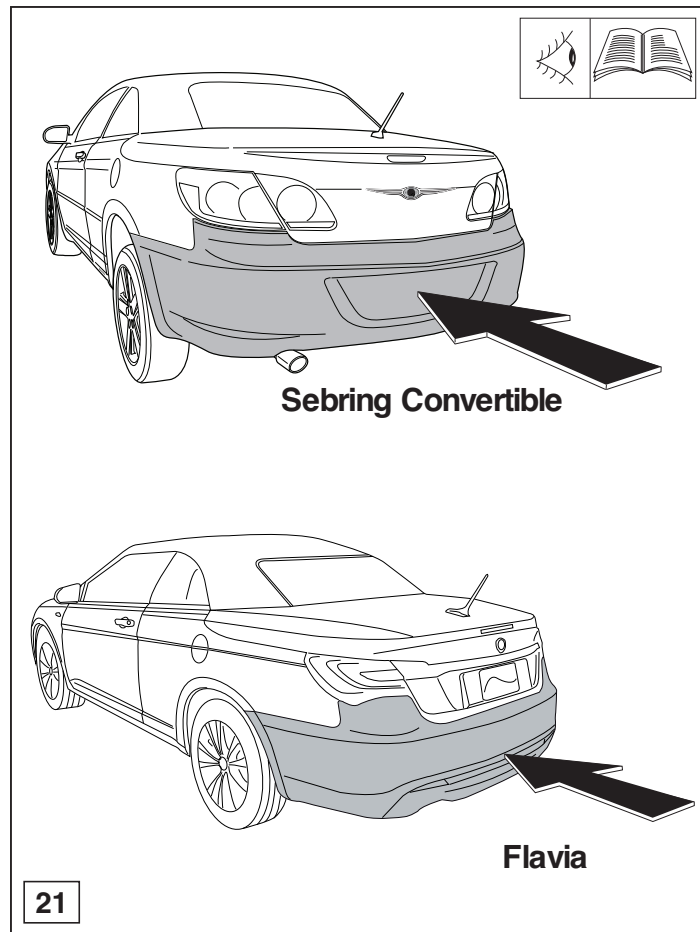
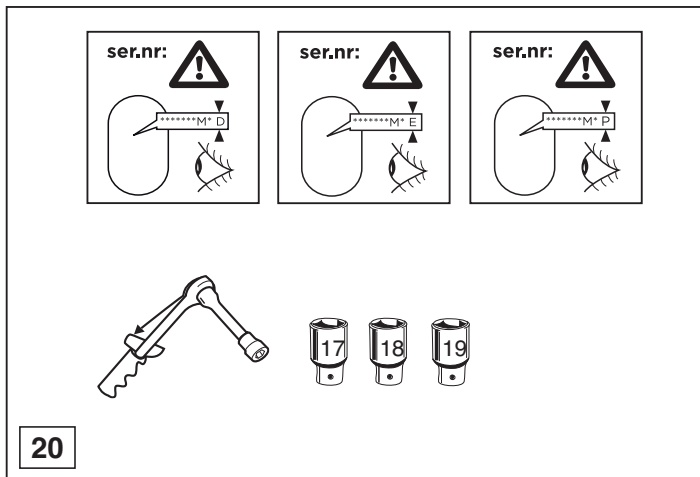



Dispositivo di traino tipo: 4637
Per autoveicoli: Chrysler Sebring (convertible) / Dodge Avenger; 2007->
Lancia Flavia; 2012->
Tipo funzionale: JSC27/JSC41/JSD41/JSL27

Classe e tipo di attacco: A50-X
Omologazione: e11 00-6364
Valore D: 9,1 kN
Carico Verticale max. S: 1500
Larghezza rimorchiabile per Caravan e T.A.T.S.: 2,45m vedere CARTA di CIRCOLAZIONE VEICOLO (motrice) + 70 cm = ..arrotondare ai 5 cm superiore (vedi D.M.28/05/85)
Massa rimorchiabile: vedi carta di circolazione dell' autoveicolo

Per verificare l'idoneità del dispositivo di traino omologato a norma CEE 94/20, all'installazione sulla vettura su cui si intende procedere al montaggio, compilare la seguente formula (se necessario declassare la massa rimorchiabile):

$$D = \frac{T \times C}{T + C} \times 0,00981 \leq 9,1 \text{ kN}$$

dove: T= Massa Complessiva Max. della motrice (in kg)
C= Massa Rimorchiabile Max. della motrice (in kg)

DA COMPILARE PER IL COLLAUDO

DICHIARAZIONE DI CORRETTO MONTAGGIO: la sottoscritta Ditta dichiara di aver montato in maniera corretta ed in conformità/ alle prescrizioni sia del costruttore del veicolo che del costruttore del dispositivo stesso il seguente dispositivo di attacco meccanico:

tipo:.....
Il dispositivo di attacco sopra indicato è stato installato su autoveicolo
modello:.....
targa:.....
Data:.....

TIMBRO e FIRMA

Si dichiara inoltre di aver informato l'utente del veicolo sull'USO e MANUTENZIONE del dispositivo stesso.

